

Control panel for Turn Table  
(Standard Motor wire length: 5m)

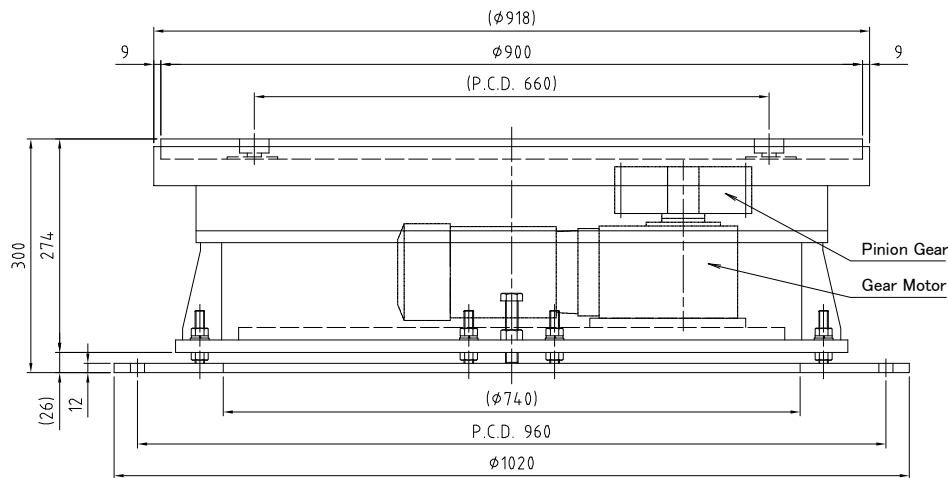

### ISB-S-09 Standard Type

Turn Table Size	Outer diameter	φ 900mm (Carring Surface)
	Height	300mm
Movable load		3500kg
Motions	Turning Direction	Clockwise and Anti-clockwise Rotation
	Rotation Speed	0.5~3.5 r.p.m.
Geared motor for drive ( without break)		0.4kW Reduction Rotation1/100 3P AC200V
Surface Finishing		Standard color Giotto blue
Device weight		425kg