

View-A

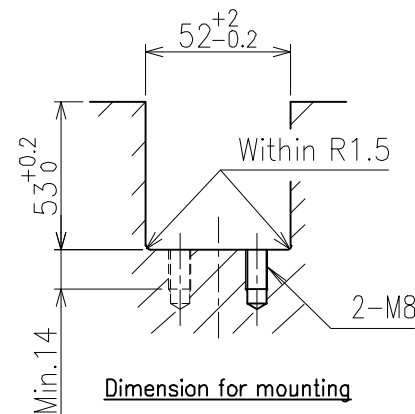

Load capacity			
No. of balls	4		
Supplied air pressure	0.4MPa	0.5MPa	0.6MPa
		{4.08kgf/cm ² }	{5.10kgf/cm ² }
Load capacity on each ball	0.98kN	1.24kN	1.51kN
	{100kgf}	{127kgf}	{154kgf}
Load capacity on each unit	3.92kN	4.98kN	6.04kN
	{400kgf}	{508kgf}	{616kgf}

>Description
 ISR-C50D Type Air Ball Lifter
 ISR-C50D-250-A Type
 Unit = mm

>Specification
 Product weight = 2.0kg
 Withstand pressure = 0.9MPa (9.18kgf/cm²)
 Working pressure range = 0.05~0.6MPa (0.51~6.12kgf/cm²)
 Operating temperature range = -5~80°C (without freezig air line)
 Using fluid = Air and inert gas (no filling up)

>Material
 Ball = SUS44C
 Plate = SUS440C
 Cap = SUS304
 O-ring = Viton
 Grease = Clean Grease
 Body = A6063-T5
 +Electroless Nickel plating
 Plug = A6063-T5
 +Electroless Nickel plating
 Bar = SGD400-D
 +Electroless Nickel plating