

>Description  
 ILS-S Type Positioning Stage  
 ILS-500S Type  
 Unit = mm

>Positioning unit specification  
 Product Weight = 3.9kg  
 Load capacity : 500kgf Max  
 Moving distance :  $\pm 30\text{mm}$ [1.181"]

Case = Aluminum+Alumite  
 Fixing flange = Aluminum+Alumite  
 Moving stage = SUS304+UHMWPE

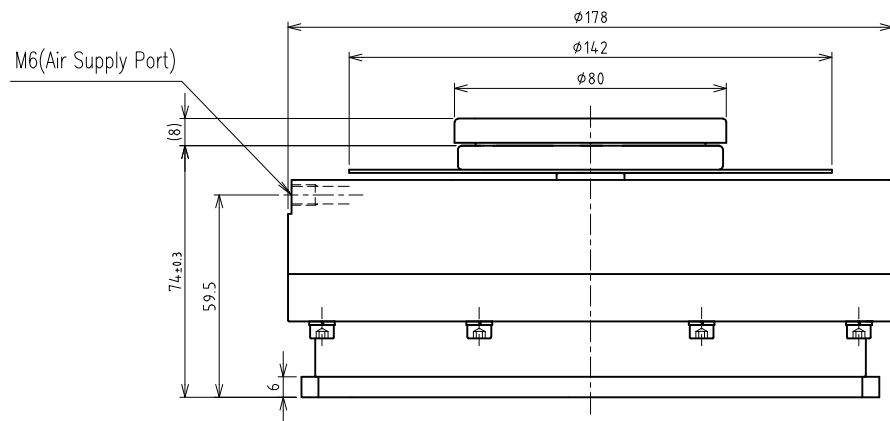

(CAUTION) when returning back the moving plate back to its original position no load should applied on the moving plate  
 Air specifications

- With stand pressure : 0.7MPa(7.14kgf/cm<sup>2</sup>)
  - Recommended air pressure : 0.4~0.6MPa (4.08~6.12kgf/cm<sup>2</sup>)
  - Operating temperature limit : 10°C~60°C
- Operating fluid : air or oil free inactive gas